

# SAILOR

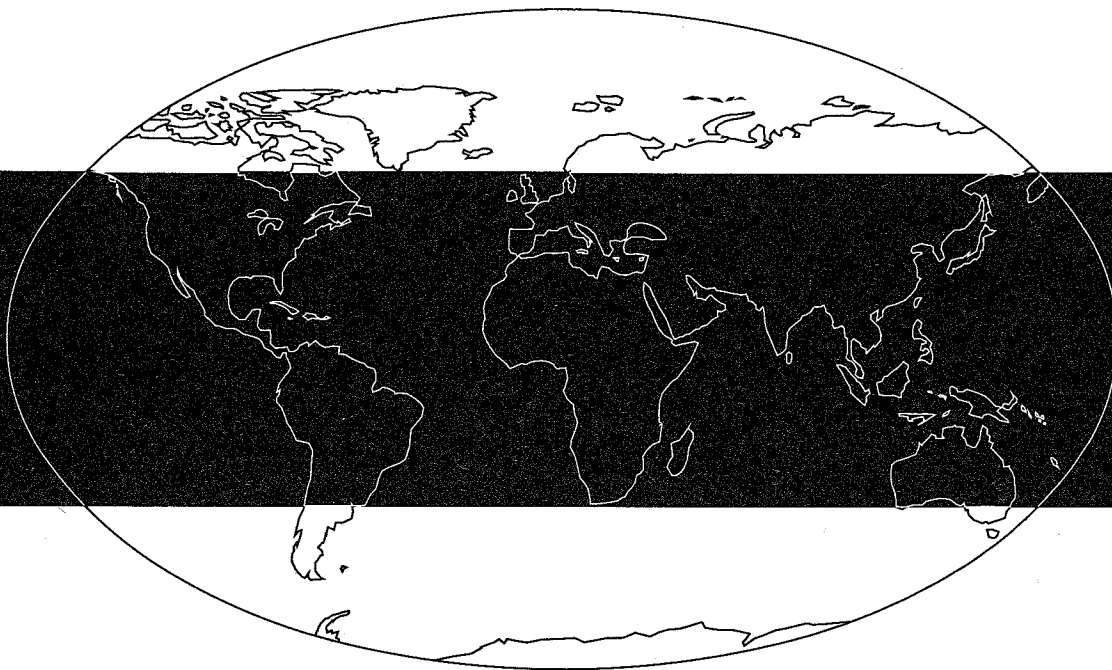

TECHNICAL MANUAL  
FOR  
COMPACT MULTI ALARM BOX H2184



S.P. RADIO A/S · AALBORG · DENMARK

**CONTENTS**

<b>1</b>	<b>GENERAL INFORMATION</b>	
1.1	INTRODUCTION	1-1
1.2	PRINCIPLE OF OPERATION AND CONTROLS	1-1
1.3	TECHNICAL DATA	1-2
1.4	BLOCK DIAGRAM	1-3
<b>2</b>	<b>INSTALLATION</b>	
2.1	DIMENSION AND DRILLING PLAN	2-1
2.2	ELECTRICAL	2-6
2.2.1	GENERAL INSTALLATION INFORMATION	2-6
2.2.2	CONNECTIONS BETWEEN H2184 AND N2174 SINGLE	2-6
2.2.3	CONNECTIONS BETWEEN H2184 AND 2 X N2174	2-7
2.2.4	CONNECTIONS BETWEEN H2184 AND RM2151 (without N2165)	2-7
2.2.5	CONNECTIONS BETWEEN H2184 AND RM2151 WITH N2165	2-7
2.2.6	CONNECTIONS BETWEEN H2184 AND INMARSAT-C	2-8
2.2.7	CONNECTIONS BETWEEN H2184 AND H2192	2-8
<b>5</b>	<b>CIRCUIT DESCRIPTION AND SCHEMATIC DIAGRAMS</b>	
5.1	KEYBOARD MODULE 1	5-1
5.2	DISPLAY MODULE 2	5-3
5.3	MULTI ALARM MODULE 3	5-4
5.4	CONNECTION BOARD MODULE 4	5-7
<b>6</b>	<b>PARTS LIST</b>	

**CONTENTS**

<b>1</b>	<b>GENERAL INFORMATION</b>	
1.1	INTRODUCTION	1-1
1.2	PRINCIPLE OF OPERATION AND CONTROLS	1-1
1.3	TECHNICAL DATA	1-2
1.4	BLOCK DIAGRAM	1-3

## 1 GENERAL INFORMATION

### 1.1 INTRODUCTION

Multi alarm box H2184 is an alarm box with five inputs, two for telex alarms, two for battery low alarms, and one for AC mains failure alarm.

It is designed for use in conjunction with the COMPACT HF SSB SYSTEM, but it can also be used as a general alarm box.

### 1.2 PRINCIPLE OF OPERATION AND CONTROLS

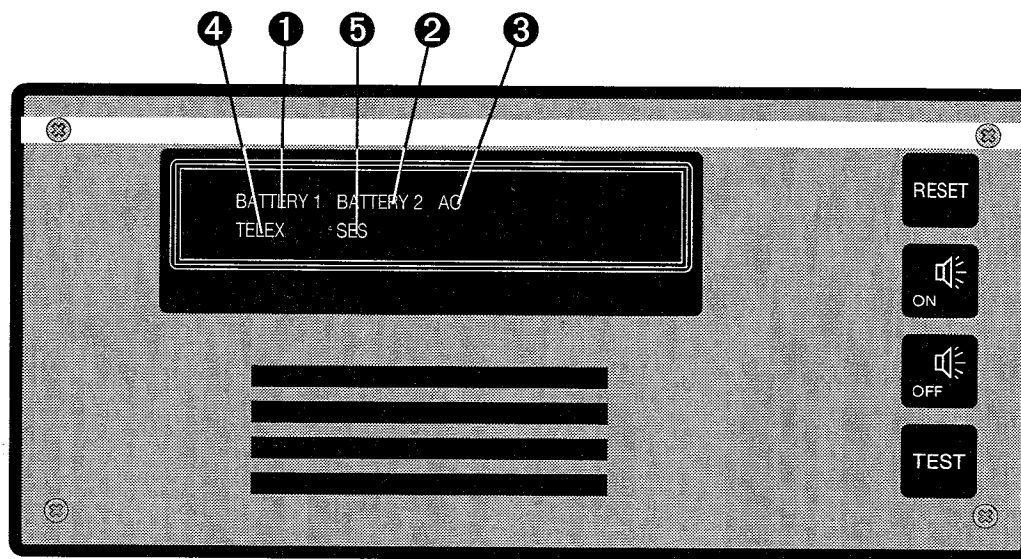

- ① Indicates that the on BATTERY 1 voltage is low, plus a continuous acoustic alarm. When reset the acoustic alarm will be switched off, but the display will remain on until the BATTERY 1 voltage is normal.
- ② Indicates that the on BATTERY 2 voltage is low, plus a continuous acoustic alarm. When reset the acoustic alarm will be switched off, but the display will remain on until the BATTERY 2 voltage is normal.
- ③ Indicates that the AC mains voltage is low, plus a continuous acoustic alarm. When reset the acoustic alarm will be switched off, but the display will remain on until the AC mains voltage is normal.
- ④ Indicates that a radio TELEX has been received, plus acoustic alarm for approx. 2 sec. (If there is a jumper in P1 the acoustic alarm will be continuous). When reset the acoustic alarm and the display will be switched off.
- ⑤ Indicates that a inmarsat-c telex SES has been received, plus acoustic alarm for approx. 2 sec. (If jumper in P the acoustic alarm is continuous). When reset the acoustic alarm and the display will be switched off.



Resets the alarms as described above.



Switches on the acoustic alarm, the TELEX and SES alarm only.



Switches off the acoustic alarm, the TELEX and SES alarm only.



Test switch for display and acoustic alarm test.

### 1.3 TECHNICAL DATA

#### POWER SOURCE:

BATTERY 1 and/or BATTERY 2.  
 Supply voltage: 17-32V DC  
 Current consumption: Max. 250 mA.

#### ALARM INPUTS:

$V_{in}$ : min. 10V, max. 32V.  
 $I_{in}$ : min. 5 mA, max. 16 mA.  
 Pulse width: min. 1 msec max. continues.  
 Front panel: Reset, test and acoustic alarm on/off switches.

#### OUTPUTS:

Battery output: 0.5 Amp fused.  
 Front panel: Visual indication and acoustic alarm.

Ambient temperature: -15°C to 55°C operating.  
 -20°C to 70°C storage.

Relative humidity: 95% non-condensing.

Vibration: IEC, CEPT and MPT 1204.

Dimension: H\*W\*D, 98mm \* 210mm \* 300mm.

Weight: 1.3 kg.

1.4 BLOCK DIAGRAM

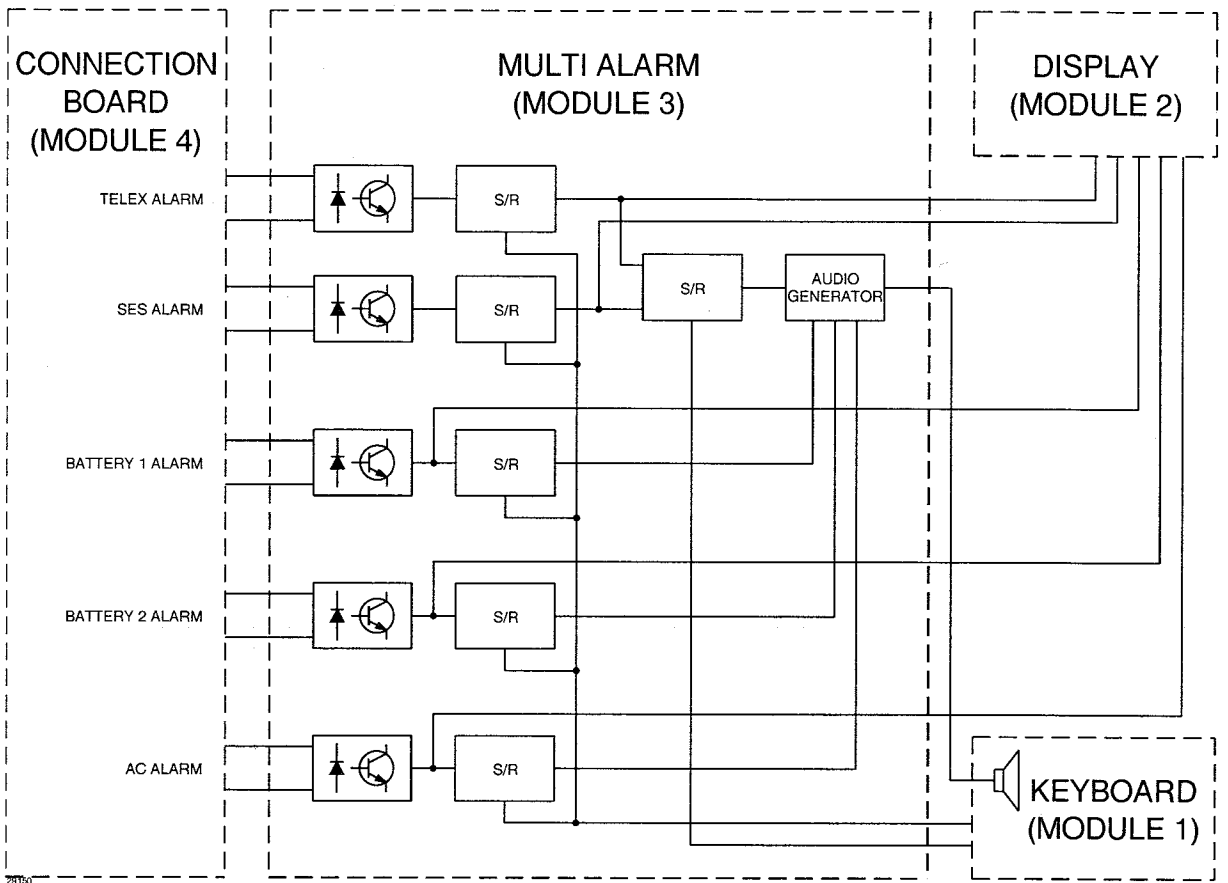

**CONTENTS**

<b>2</b>	<b>INSTALLATION</b>	
2.1	DIMENSION AND DRILLING PLAN	2-1
2.2	ELECTRICAL	2-6
2.2.1	GENERAL INSTALLATION INFORMATION	2-6
2.2.2	CONNECTIONS BETWEEN H2184 AND N2174 SINGLE	2-6
2.2.3	CONNECTIONS BETWEEN H2184 AND 2 X N2174	2-7
2.2.4	CONNECTIONS BETWEEN H2184 AND RM2151 (without N2165)	2-7
2.2.5	CONNECTIONS BETWEEN H2184 AND RM2151 WITH N2165	2-7
2.2.6	CONNECTIONS BETWEEN H2184 AND INMARSAT-C	2-8
2.2.7	CONNECTIONS BETWEEN H2184 AND H2192	2-8

## 2 INSTALLATION

### 2.1 DIMENSION AND DRILLING PLAN

#### MOUNTING POSSIBILITIES

##### BULKHEAD MOUNTED WITHOUT MOUNTING BRACKET

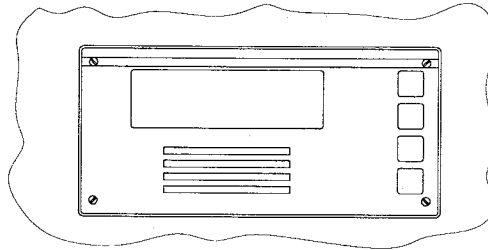
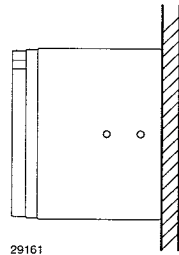

#### DRILLING PLAN

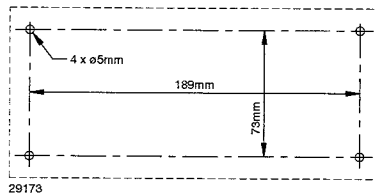

##### INSTALLATION USING THE MULTI-PURPOSE MOUNTING BRACKET

This mounting bracket is as supplied together with the H2184. It permits a wide variety of installation possibilities such as tabletop, bulkhead or deckhead. It is easy to tilt the unit by loosen the two buttons

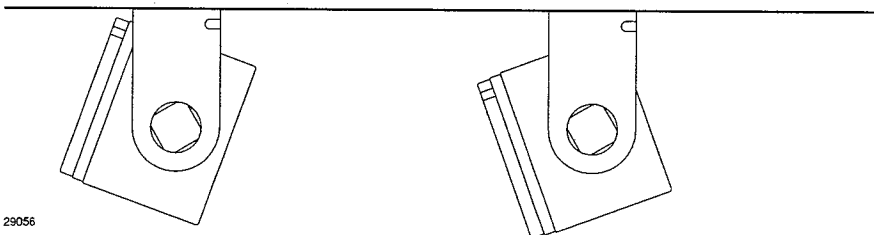
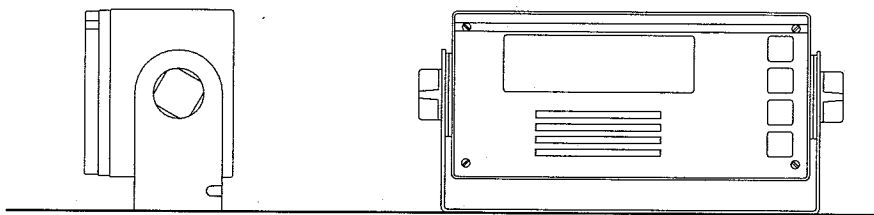



**DIMENSIONS**

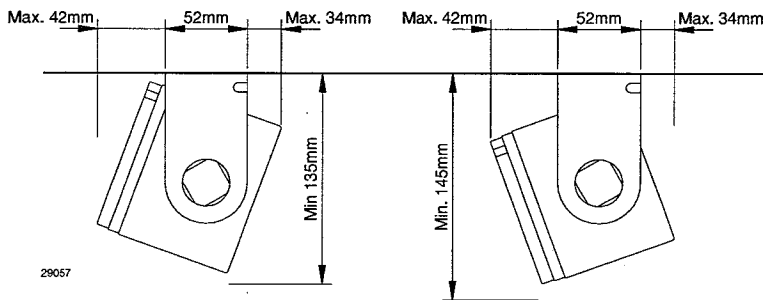
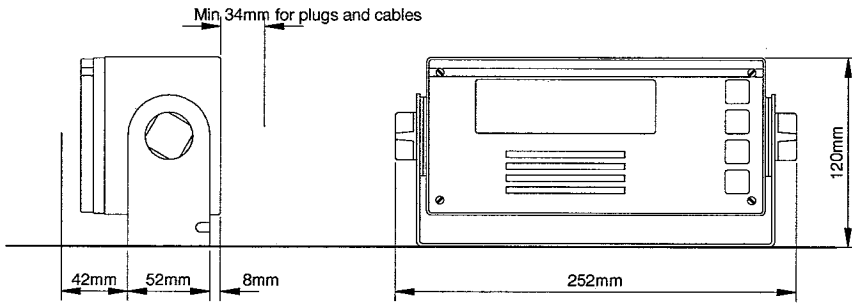
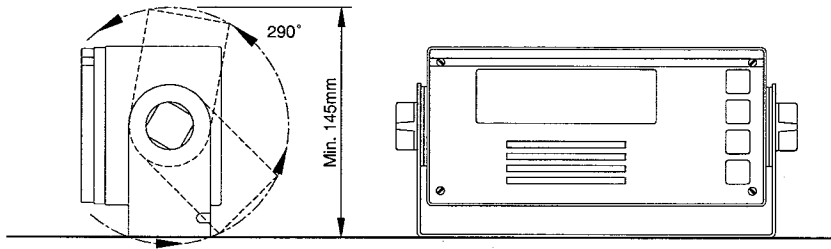

**DRILLING PLAN**

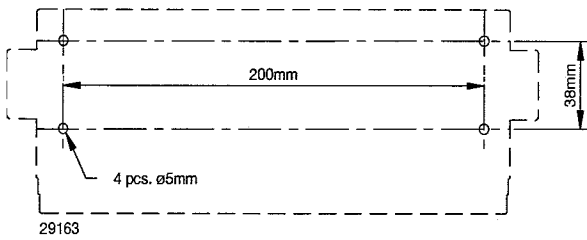

**WEIGHT**

Mounting bracket H2077:  
Multi alarm box H2184:

0.4 kg  
1.3 kg

### H2063 CONSOLE MOUNTING KIT FOR 1/4 BOX

This mounting kit is used for console flush mounting of 1/4 box, mini 1/4 box and the H2184 using the two supplied brackets.

### H2063

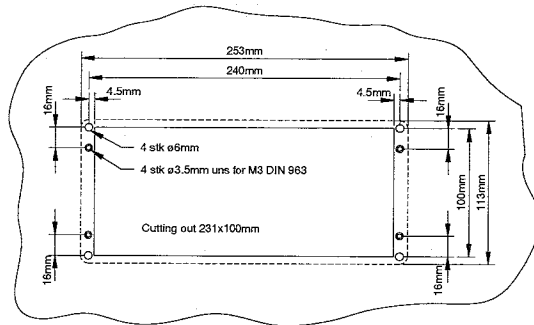
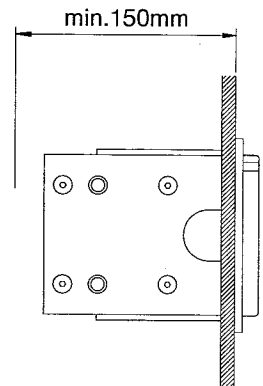
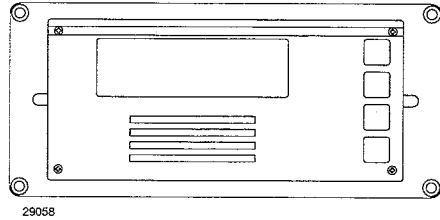

### WEIGHT

Mounting kit H2063: 1.0 kg  
Multi alarm box H2184: 1.3 kg  
Max. ambient temperature 40°C

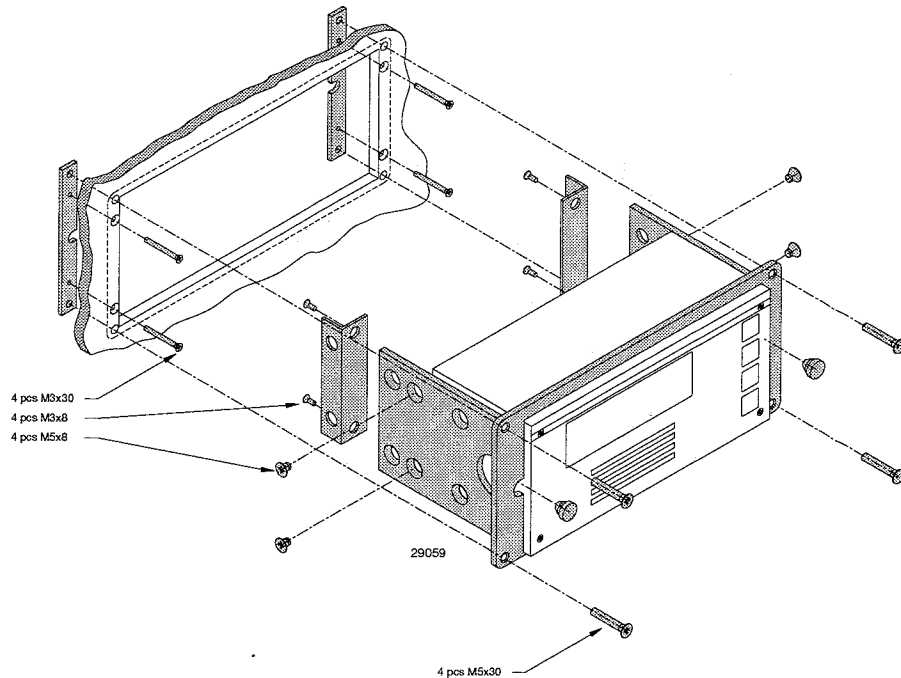

**H2062 CONSOLE MOUNTING KIT FOR 2 X 1/4 BOX**

This mounting kit is used for console flush mounting of 2 x 1/4 box, mini 1/4 box and the H2184 using the two supplied brackets.

**H2062**

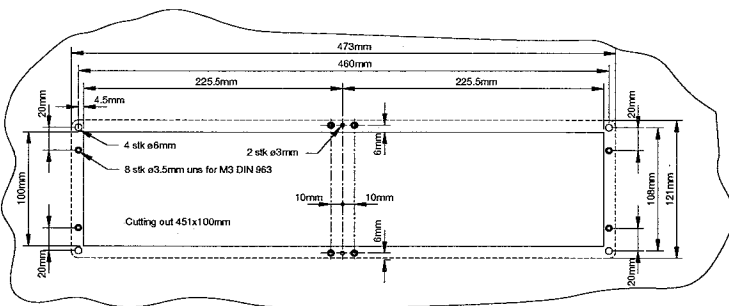
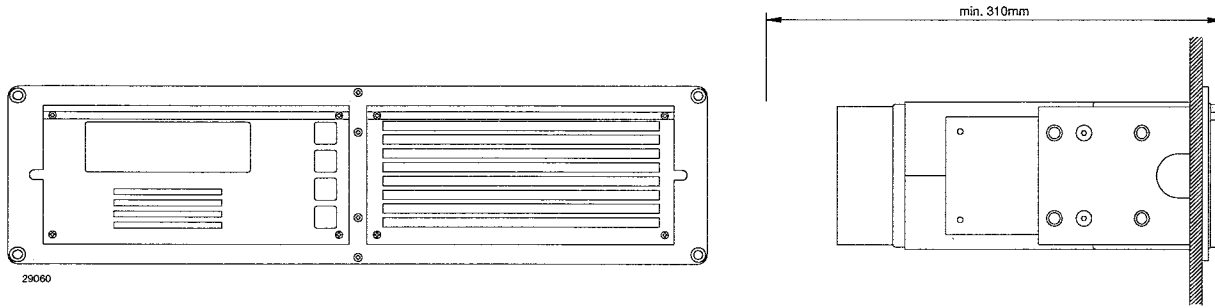

**WEIGHT**

Mounting kit H2062:	1.5 kg
Loudspeaker H2054:	5.5 kg
Loudspeaker H2074:	4.0 kg
Multi Alarm Box H2184:	1.3 kg
Max. ambient temperature 40°C	

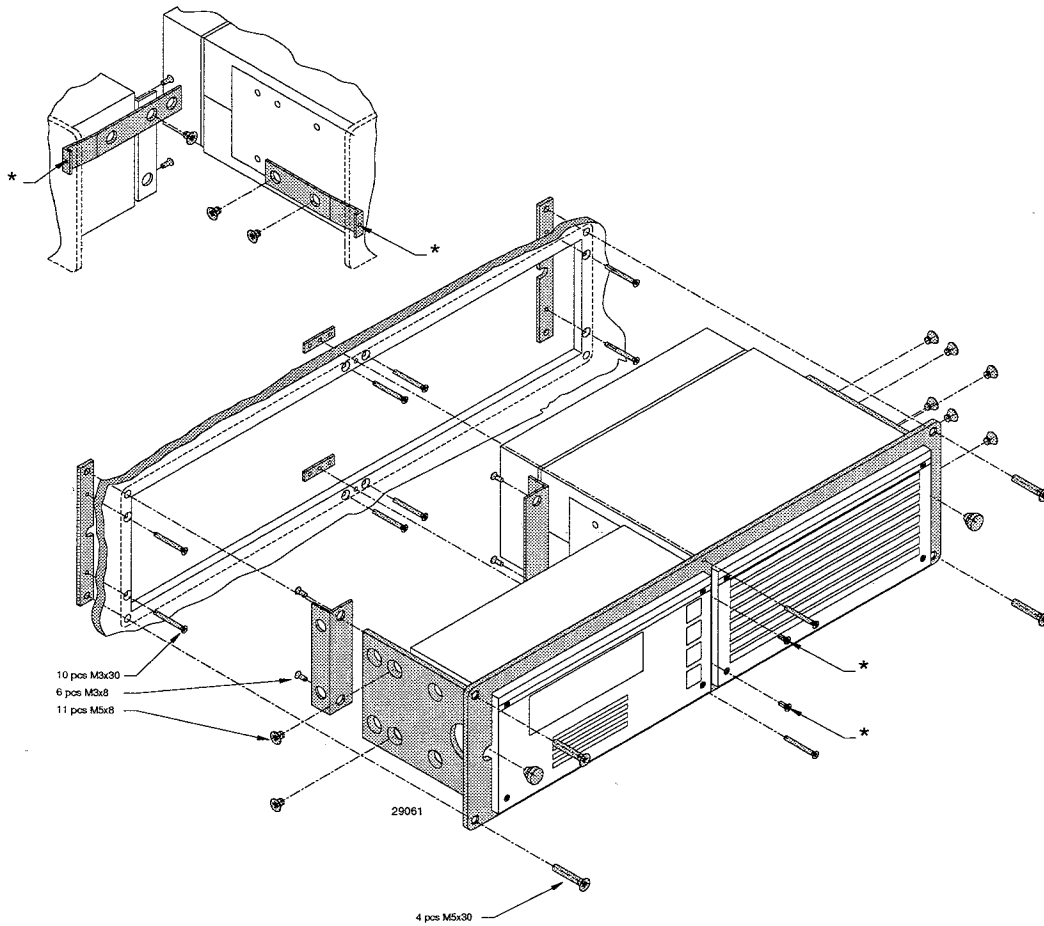

**H2064 CONSOLE MOUNTING KIT FOR 2 X 1/4 BOX**

This mounting kit is used for console flush mounting of 2 x 1/4 box, mini 1/4 box and the H2184 using the two supplied brackets.

**H2064**

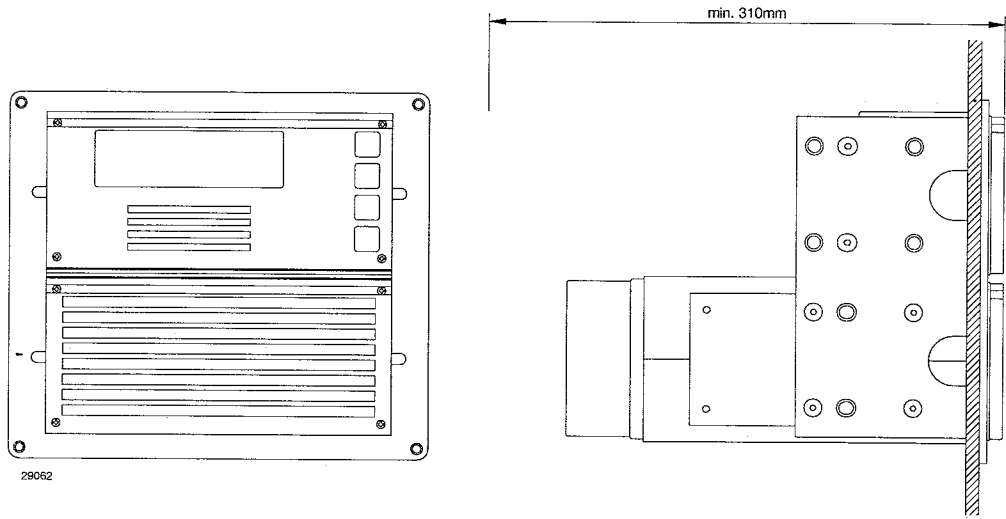

29062

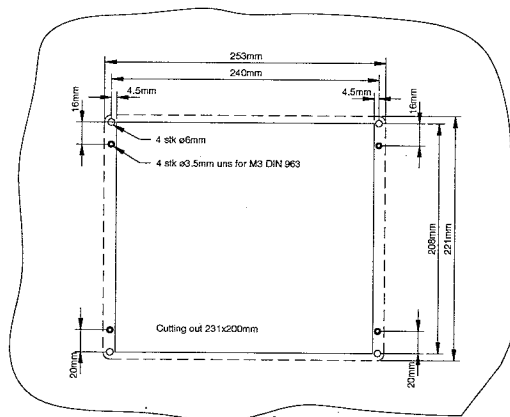

**WEIGHT**

Mounting kit H2064:	1.5 kg
Loudspeaker H2054:	5.5 kg
Loudspeaker H2074:	4.0 kg
Multi Alarm Box H2184:	1.3 kg
Max. ambient temperature 40°C	

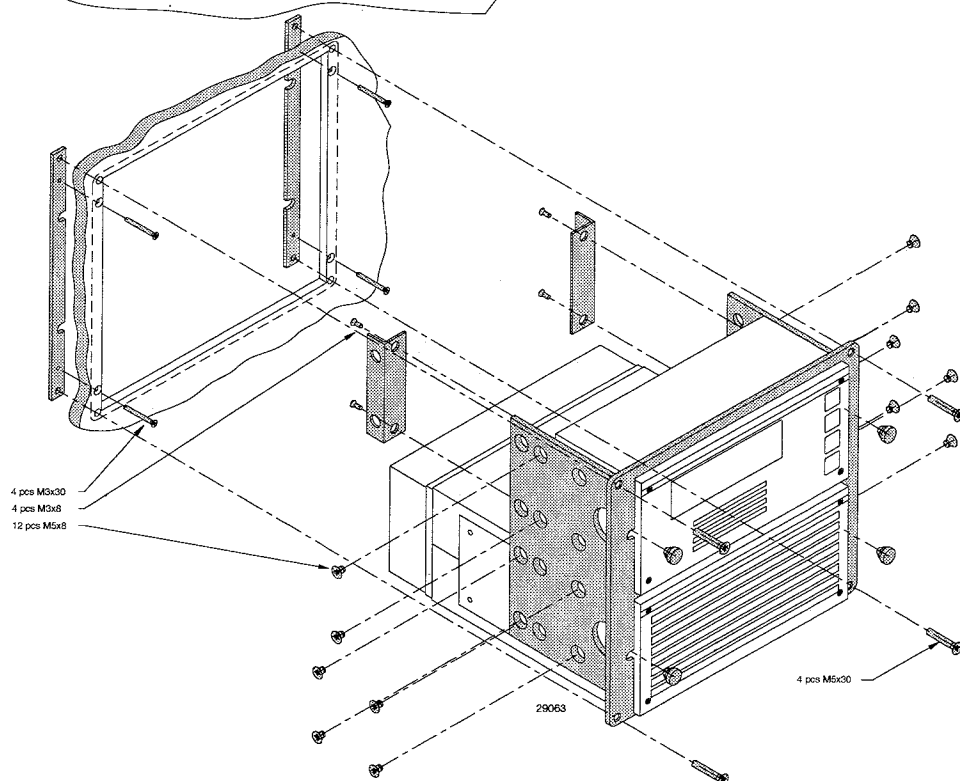

## 2.2 ELECTRICAL

### 2.2.1 GENERAL INSTALLATION INFORMATION

For detailed information about the location of terminals/plucks, please refer to the manual for the unit in question.

All cabling can be any multicable with minium 0.5 mm<sup>2</sup> cores.

### DISASSEMBLING FOR INSTALLATION

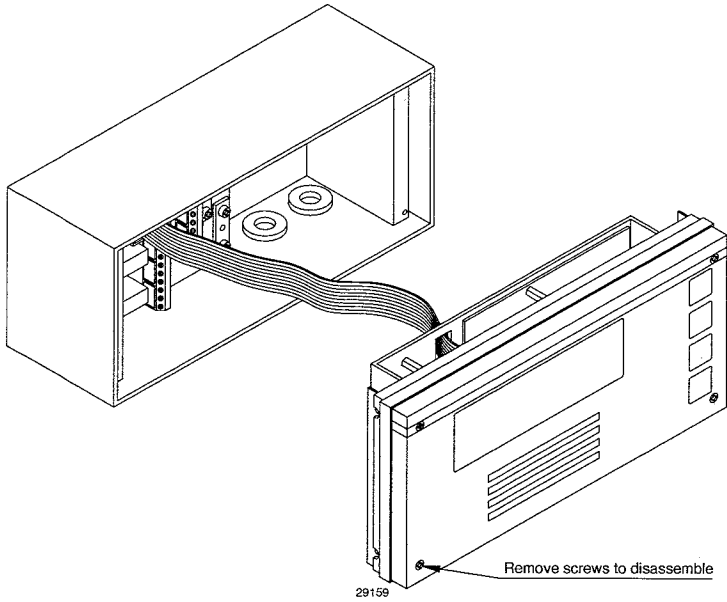

### 2.2.2 CONNECTIONS BETWEEN H2184 AND N2174 SINGLE

H2184		N2174 CONN. SINGLE B.C. (3)		SIGNAL
ST2	ST1	ST3	ST5	
	3		2	+ BATT 1 INPUT / + BATT
	4		1	- BATT 1 INPUT / - BATT
5	10			+ AC ALARM / + BATT OUTPUT
6		7		- AC ALARM
	11	8		- BATT OUTPUT
9	14			- BATT 1 ALARM / + BATT OUTPUT
10		4		- BATT 1 ALARM
	15	5		- BATT OUTPUT

### 2.2.3 CONNECTIONS BETWEEN H2184 AND 2 X N2174

H2184		N2174 - I BATTERY 1 ALARM & AC ALARM		N2174 - II BATTERY 2 ALARM		SIGNAL
ST2	ST1	ST1	ST3	ST7	ST9	
	1				2	+ BATT 2 INPUT / + BATT
	2				1	- BATT 2 INPUT / + BATT
	3		2			+ BATT 1 INPUT / + BATT
	4		1			- BATT 1 INPUT / - BATT
5	10					+ AC ALARM / + BATT OUTPUT
6		7				- AC ALARM
	11	8				- BATT OUTPUT
7	12					+ BATT 2 ALARM / + BATT OUTPUT
8				4		- BATT 2 ALARM
	13			5		- BATT OUTPUT
9	14					+ BATT 1 ALARM / + BATT OUTPUT
10						- BATT 1 ALARM
	15	5				- BATT OUTPUT

### 2.2.4 CONNECTIONS BETWEEN H2184 AND RM2151 (without N2165)

H2184		RM2151		SIGNAL
ST2	ST1	P2-5	COLOUR	
3		12	WHITE	+ TLX ALARM / + 18V
4		4	PINK	- TLX ALARM / EXT. ALARM
	(1)			+ BATT 2 INPUT
	(2)			- BATT 2 INPUT
	3			+ BATT 1 INPUT
	4			- BATT 1 INPUT

### 2.2.5 CONNECTIONS BETWEEN H2184 AND RM2151 WITH N2165

H2184		N2165		SIGNAL
ST2	ST1	ST2	ST6	
3	8			+ BATT. OUTPUT
4		6		- TLX ALARM / EXT. ALARM NC
	9	7		- BATT OUTPUT / EXT. ALARM C
(1)			(3)	+ BATT 2 INPUT / + BATT. OUT
(2)			(4)	- BATT 2 INPUT / + BATT. OUT
3			3	+ BATT 1 INPUT / + BATT. OUT
4			4	- BATT 1 INPUT / - BATT. OUT

**2.2.6 CONNECTIONS BETWEEN H2184 AND INMARSAT-C**

H2184		H2198	SIGNAL
ST2	ST1	COM-1	
2		5	- SES ALARM / GND
1		9	+ SES ALARM / RING INDICATOR
	1		+ BATT 2 INPUT
	2		- BATT 2 INPUT
	3		+ BATT 1 INPUT
	4		- BATT 1 INPUT

**2.2.7 CONNECTIONS BETWEEN H2184 AND CONSOLE H2192**

H2184		RM2151 RADIO TELEX	H2198 INMARSAT-C	SIGNAL
ST2	ST1	H2192 CONNECTION BOARD (1)	H2192 CONNECTION BOARD (2)	
		ST7	ST2	
	1			+ BATT 2 INPUT
	2			- BATT 2 INPUT
	3			+ BATT 1 INPUT
	4			- BATT 1 INPUT
3	8			+ TLX ALARM / + BATT. OUTPUT
4		2		- TLX ALARM / EXT ALARM NO
	9	3		- BATT. OUTPUT / EXT ALARM
2			2	- SES ALARM/GND
1			1	+ SES ALARM / RING INDICATOR

**CONTENTS**

<b>5</b>	<b>CIRCUIT DESCRIPTION AND SCHEMATIC DIAGRAMS</b>	
5.1	KEYBOARD MODULE 1	5-1
5.2	DISPLAY MODULE 2	5-3
5.3	MULTI ALARM MODULE 3	5-4
5.4	CONNECTION BOARD MODULE 4	5-7



5 CIRCUIT DESCRIPTION AND SCHEMATIC DIAGRAMS

5.1 KEYBOARD MODULE 1

COMPONENT LOCATION

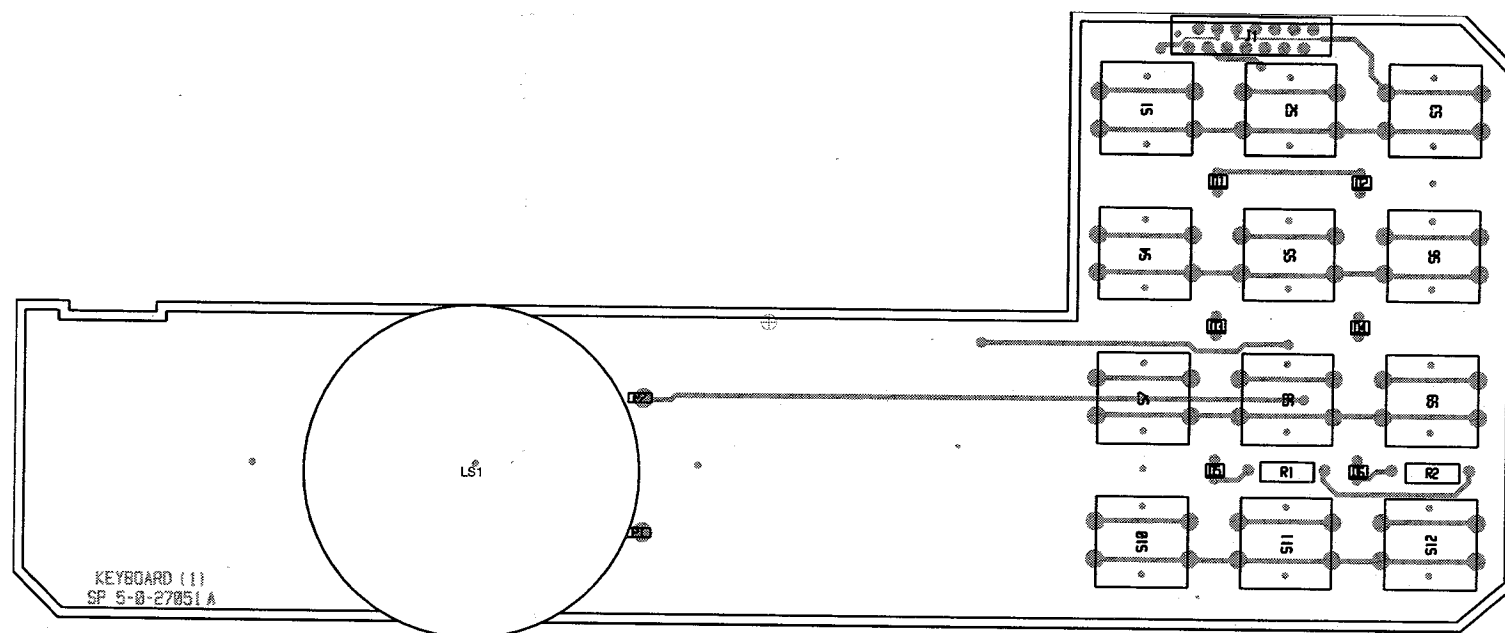

Seen from component side with upper side tracks

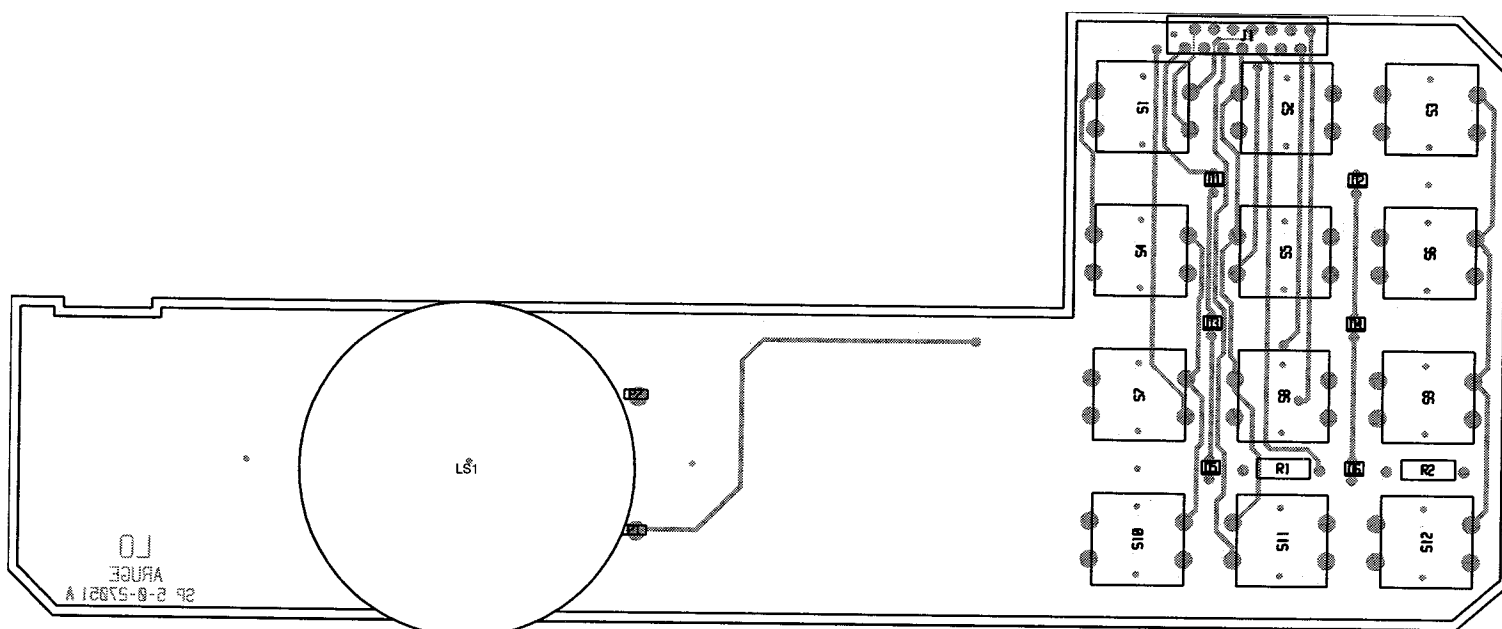

Seen from component side with lower side tracks  
PCB rev. 27051A

KEYBOARD MODULE 1

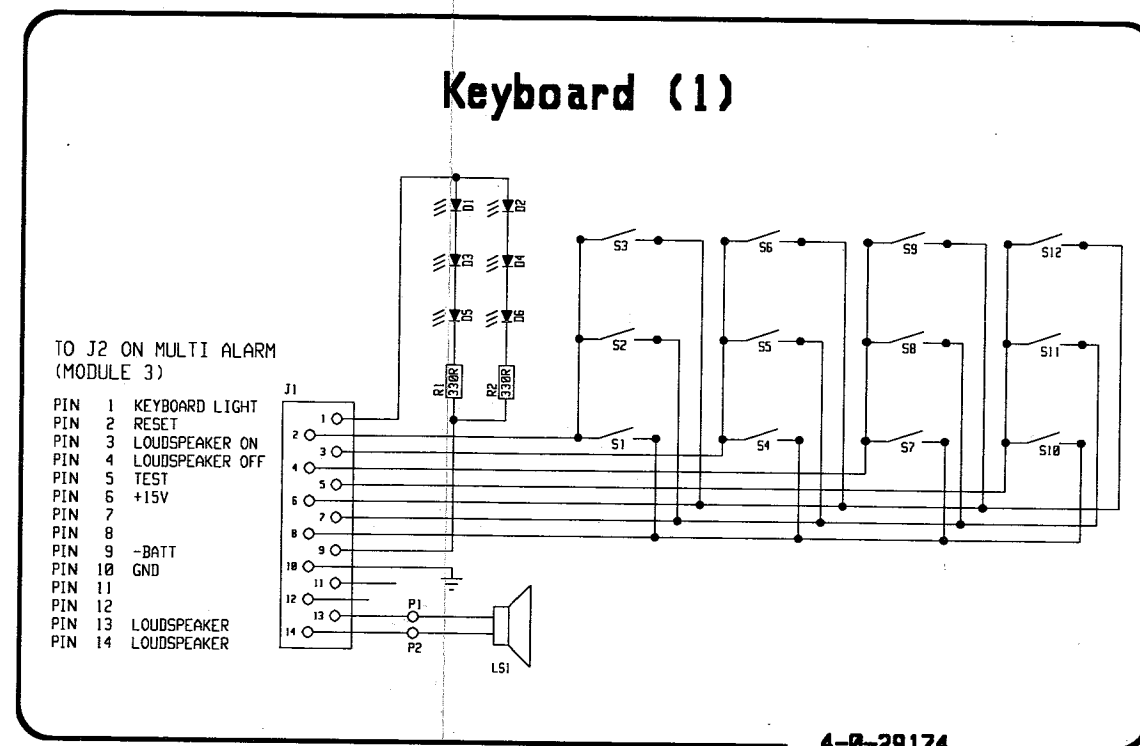

This diagram is valid for PCB rev. 27051A



5.2 DISPLAY MODULE 2

COMPONENT LOCATION

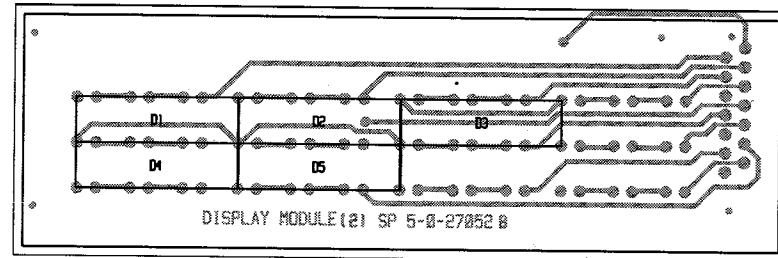

Seen from component side with upper side tracks

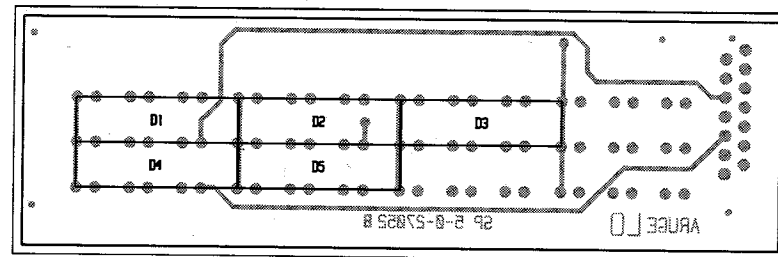

Seen from component side with lower side tracks  
PCB rev. 27052B

DISPLAY MODULE 2

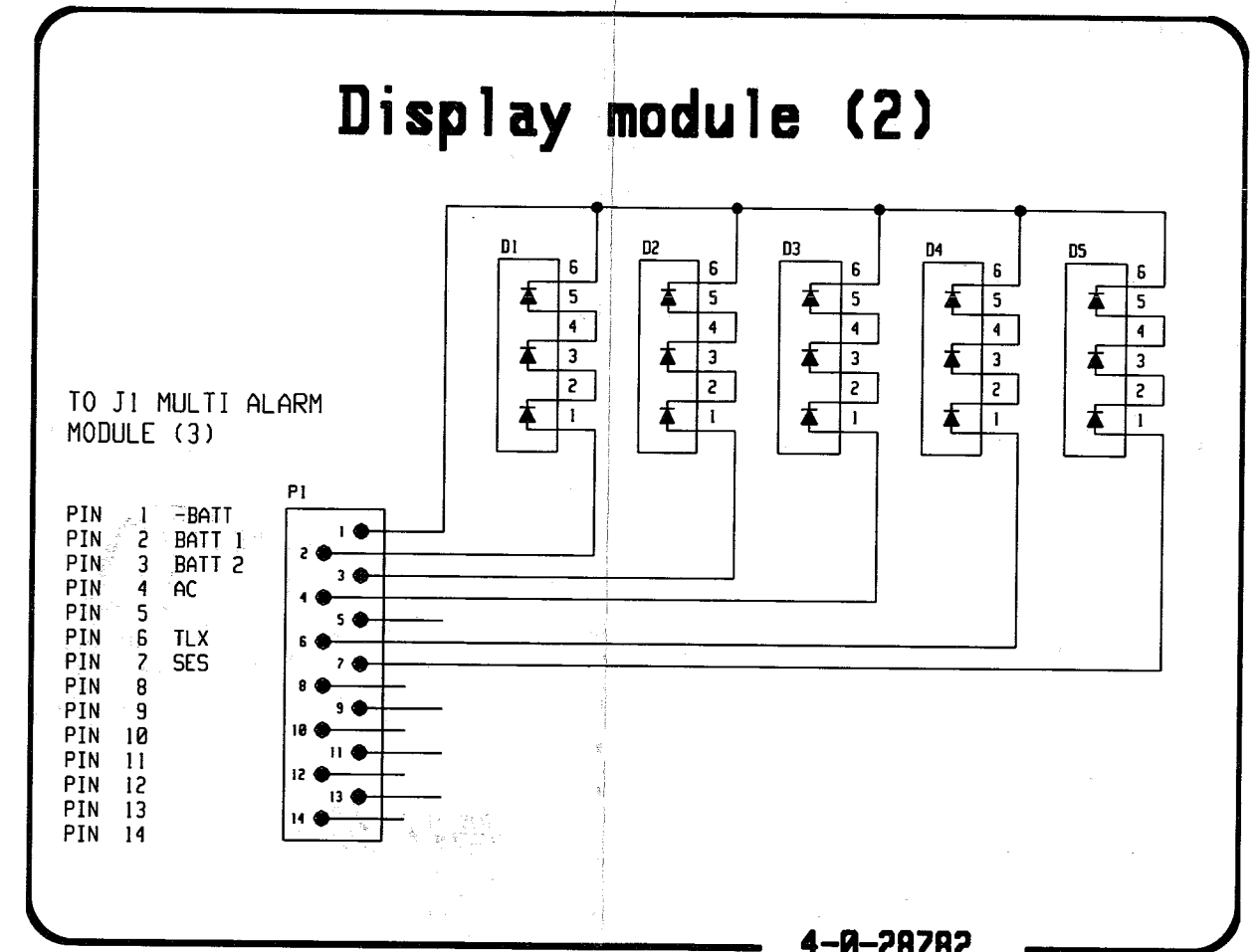

This diagram is valid for PCB rev. 27052B

**5.3 MULTI ALARM MODULE 3**

The five alarm inputs are in principle equal, therefore only one input will be described. When an alarm is received at one of the inputs eg. SES ALARM (INMARSAT-C), the following will take place.

Current will flow through the diode in OC1.1. Now the transistor in OC1.1 will saturate and course a high pulse to U1 pin 4. The R-S flip flop (U1) will set  $Q_0$  to high.  $Q_0$  is connected to a lightbar in the frontpanel display, which will light up now.

The signals from U1 pin2 and pin9 are feed to U4.1, which combines the two telex alarms. The output of U4.1 is feed to a timing circuit C22 and R22, which will start the acoustic alarm for approx. 2 sec. The time constant can be disabled by inserting the jumper in P1.

U4.3 combines the signal from the telex and battery alarms. The output from U4.3 is connected to an audio oscillator U3.1/U3.2. The output is fed to the output amplifier Q2.

By inserting a jumper in P2 you can increase the audio level.

The light bars for battery low indication are connected directly to the input optocouplers, therefore the lightbars will stay on, as long as the battery low alarm signals are received.

**COMPONENT LOCATION**

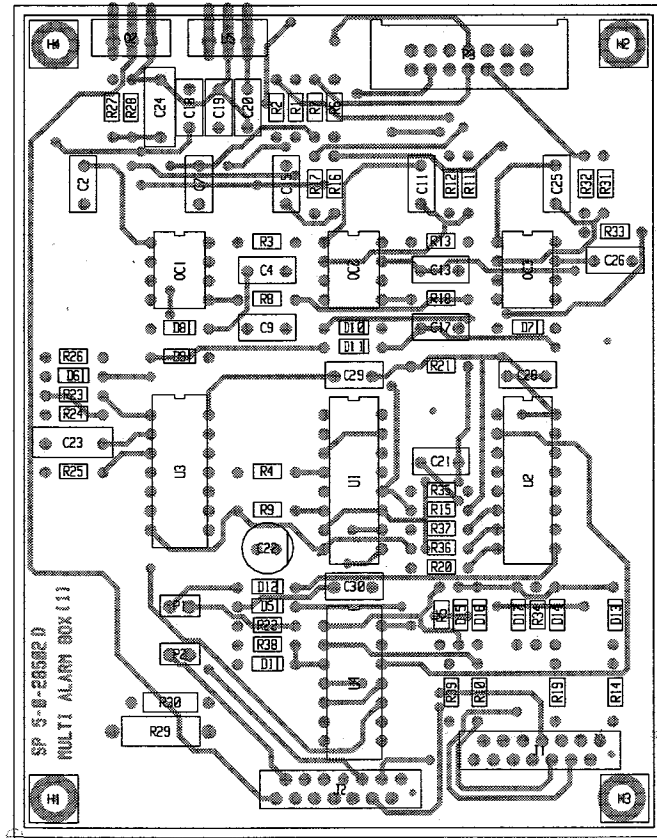

Seen from component side with upper side tracks  
PCB rev. 28502D

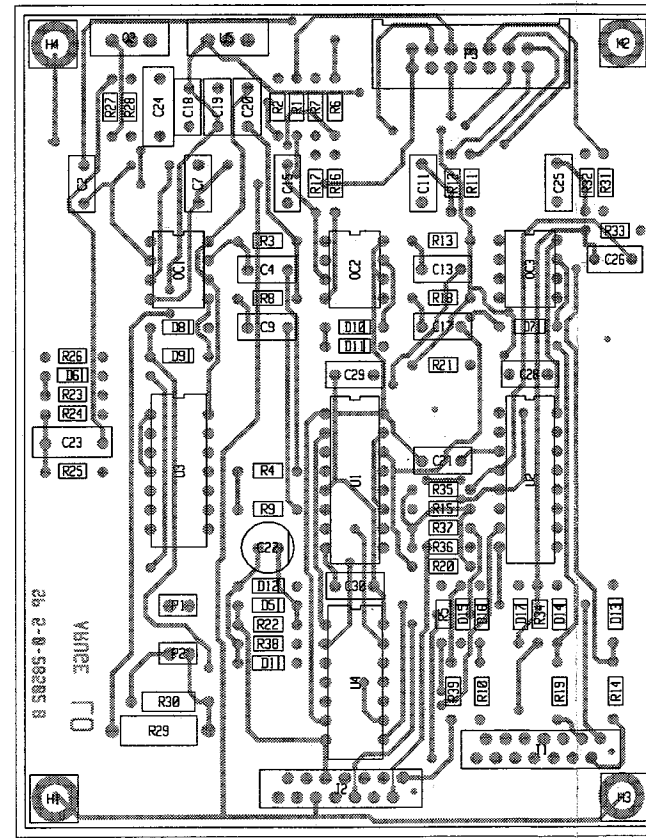

Seen from component side with lower side tracks

MULTI ALARM MODULE 3

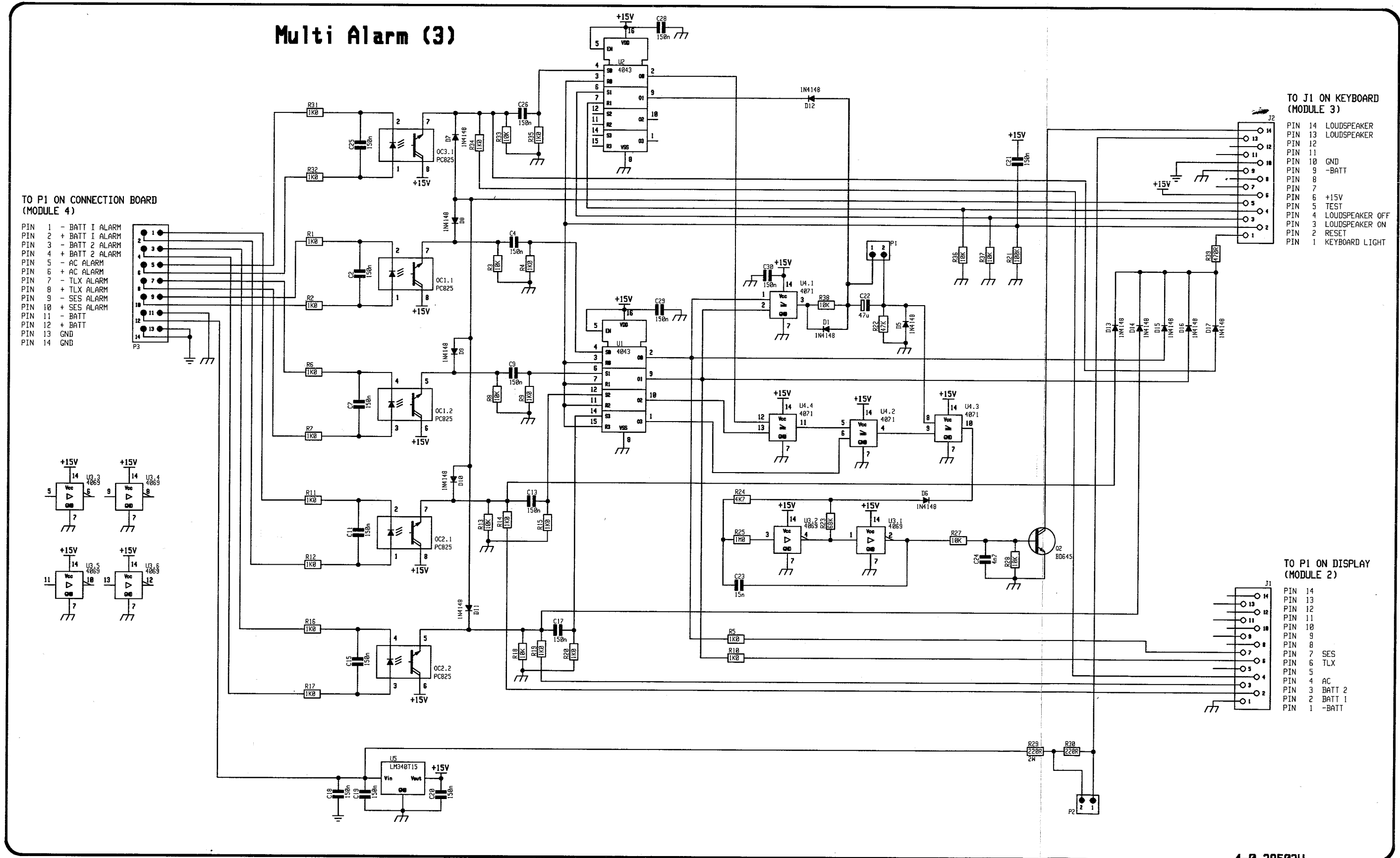

4-0-28502H



5.4 CONNECTION BOARD 4

COMPONENT LOCATION

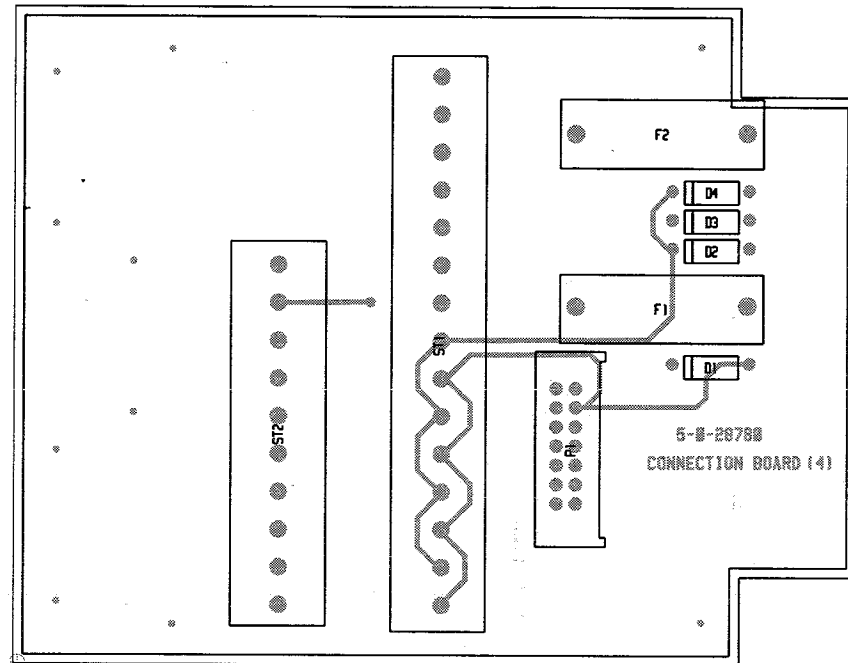

Seen from component side with upper side tracks

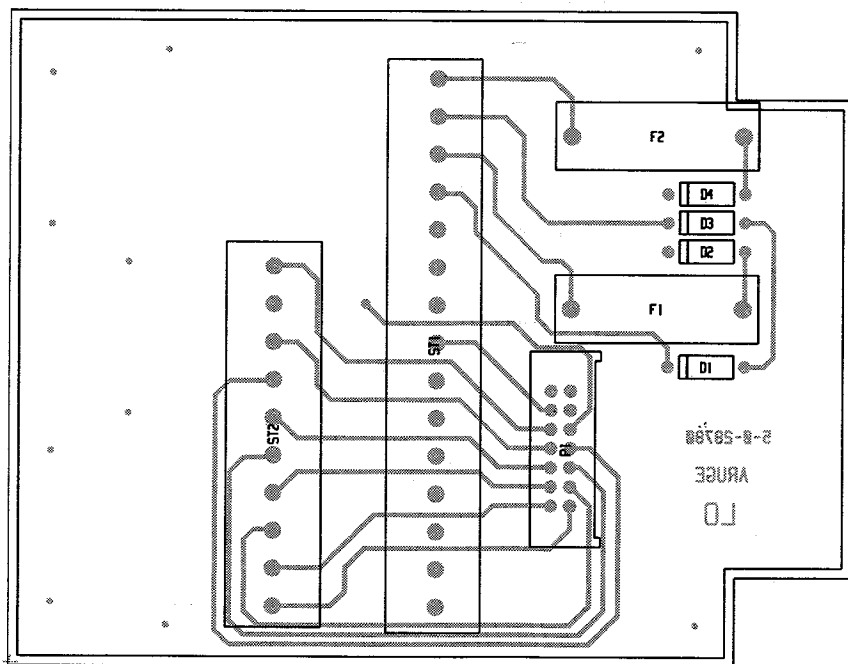

Seen from component side with lower side tracks  
PCB rev. 28780

CONNECTION BOARD MODULE 4

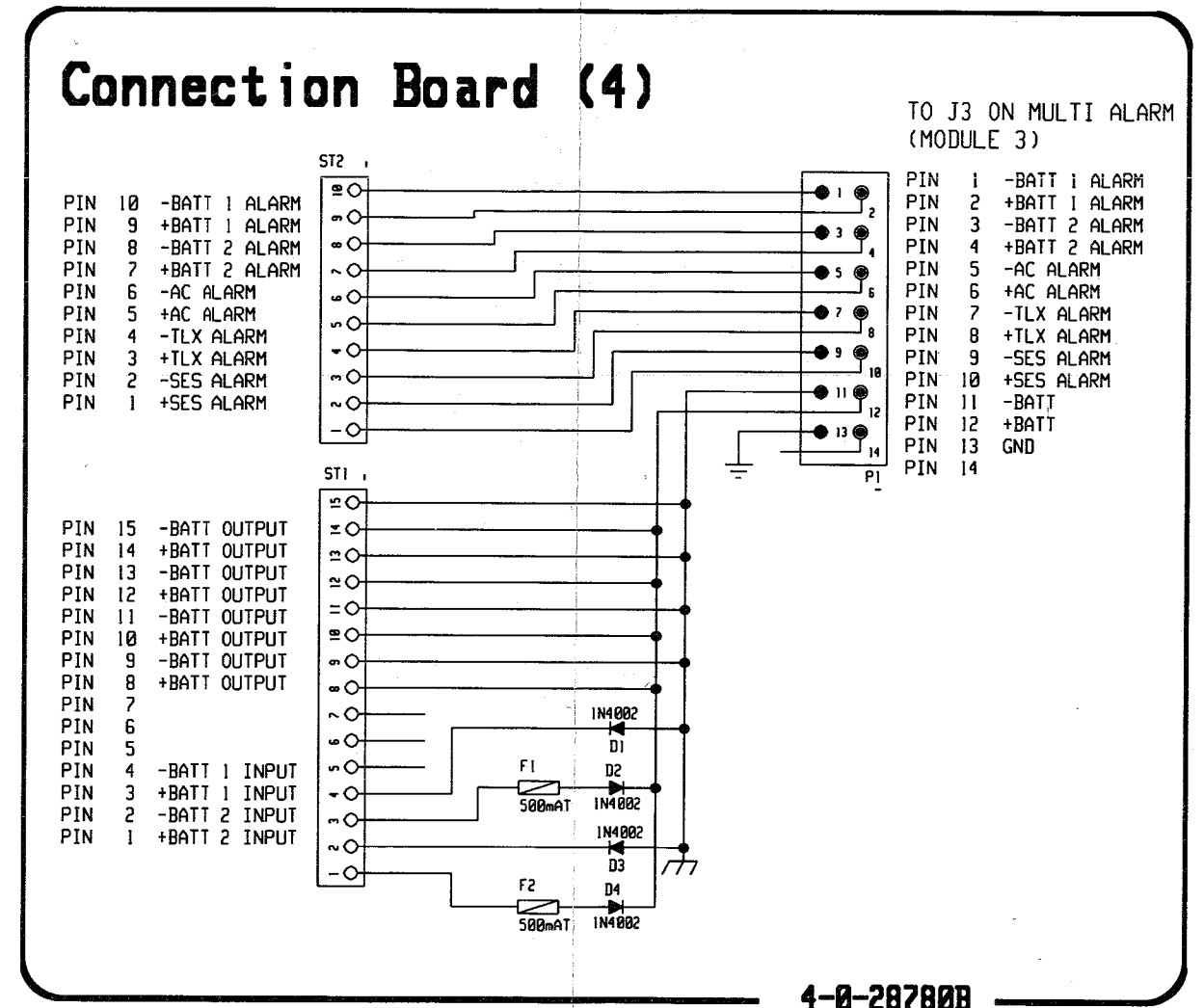

This diagram is valid for PCB rev. 28780

**CONTENTS**

**6 PARTS LIST**



## 6 PARTS LIST

MULTI ALARM BOX H2184		SAILOR GREEN	S.P.RADIO A/S MULTI ALARM BOX H2184 802184		
POSITION	DESCRIPTION		MANUFACTOR	TYPE	PART NO.
VARIOUS	CABINET H2184	MULTI ALARM BOX H2184	S.P.RADIO A/S	228774 / 14102400	22877400
VARIOUS	KEYBOARD FOIL H2184	MULTI ALARM BOX H2184	S.P.RADIO A/S	1-0-28779 / 9-3-28778	228779
VARIOUS	FRONTPLATE H2184	MULTI ALARM BOX H2184	S.P.RADIO A/S	228913/14102700/14302700	22891300
VARIOUS	INTERCONNECTION CABLE	14 POLES L=125mm	S.P.RADIO	3-0-27411	527411
VARIOUS	INTERCONNECTION CABLE	14 POLES L=185mm	ESPERA	3-0-28609	528609
VARIOUS	JUMPER KIT 6/1200W 726391	HF SSB 600/1200W	ESPERA	0-0-27767	727767
VARIOUS	MANUAL H2184 ENGLISH		S.P.RADIO A/S		M2184GB
-1	KEYBOARD MODULE (1)	C2149/H2184	ECI A/S	5-0-27051A / 4-0-29174	627051
-2	DISPLAY MODULE (2)	H2184		5-0-27052B / 4-0-28782	628782
-3	MULTI ALARM MODULE (3)	H2184	ECI A/S	5-0-28502D / 4-0-28502H	628502
-4	CONNECTION BOARD (4)	H2184		5-0-28780 / 4-0-28780B	628780

KEYBOARD MODULE (1)		C2149/H2184	ECI A/S	5-0-27051A / 4-0-29174	627051
POSITION	DESCRIPTION		MANUFACTOR	TYPE	PART NO.
D1-1	DIODE LIGHT EMITTING	SUB MINIATURE YELLOW	H.P.	HLMP-7019	25.649
D2-1	DIODE LIGHT EMITTING	SUB MINIATURE YELLOW	H.P.	HLMP-7019	25.649
D3-1	DIODE LIGHT EMITTING	SUB MINIATURE YELLOW	H.P.	HLMP-7019	25.649
D4-1	DIODE LIGHT EMITTING	SUB MINIATURE YELLOW	H.P.	HLMP-7019	25.649
D5-1	DIODE LIGHT EMITTING	SUB MINIATURE YELLOW	H.P.	HLMP-7019	25.649
D6-1	DIODE LIGHT EMITTING	SUB MINIATURE YELLOW	H.P.	HLMP-7019	25.649
J1-1	SOCKET	2x7 POLES	AMP	1-215079-4	78.196
P1-1	SOLDER LUG	PCB VERSION	VOGT AG	01015/Bz-Sn	82.005
P2-1	SOLDER LUG	PCB VERSION	VOGT AG	01015/Bz-Sn	82.005
R1-1	RESISTOR MF	330 OHM 5% 0.4W	PHILIPS	2322 181 53331	01.187
R2-1	RESISTOR MF	330 OHM 5% 0.4W	PHILIPS	2322 181 53331	01.187
S1-1	SWITCH KEYBOARD	12x12mm	OMRON	B3F-4005	43.601
S2-1	SWITCH KEYBOARD	12x12mm	OMRON	B3F-4005	43.601
S3-1	SWITCH KEYBOARD	12x12mm	OMRON	B3F-4005	43.601
S4-1	SWITCH KEYBOARD	12x12mm	OMRON	B3F-4005	43.601
S5-1	SWITCH KEYBOARD	12x12mm	OMRON	B3F-4005	43.601
S6-1	SWITCH KEYBOARD	12x12mm	OMRON	B3F-4005	43.601
S7-1	SWITCH KEYBOARD	12x12mm	OMRON	B3F-4005	43.601
S8-1	SWITCH KEYBOARD	12x12mm	OMRON	B3F-4005	43.601
S9-1	SWITCH KEYBOARD	12x12mm	OMRON	B3F-4005	43.601
S10-1	SWITCH KEYBOARD	12x12mm	OMRON	B3F-4005	43.601
S11-1	SWITCH KEYBOARD	12x12mm	OMRON	B3F-4005	43.601
S12-1	SWITCH KEYBOARD	12x12mm	OMRON	B3F-4005	43.601

DISPLAY MODULE (2)		H2184		5-0-27052B / 4-0-28782	628782
POSITION	DESCRIPTION		MANUFACTOR	TYPE	PART NO.
D1-2	LIGHT BAR	RED 4.5x20mm	ROHM	LD701VR	25.700
D2-2	LIGHT BAR	RED 4.5x20mm	ROHM	LD701VR	25.700
D3-2	LIGHT BAR	RED 4.5x20mm	ROHM	LD701VR	25.700
D4-2	LIGHT BAR	RED 4.5x20mm	ROHM	LD701VR	25.700
D5-2	LIGHT BAR	RED 4.5x20mm	ROHM	LD701VR	25.700
P1-2	CABLE TERMINAL	14 POLES FLAT CABLE	AMP	1-215570-4	78.276

MULTI ALARM MODULE (3)		H2184		5-0-28502D / 4-0-28502H	628502
POSITION	DESCRIPTION		MANUFACTOR	TYPE	PART NO.
C2-3	CAPACITOR MKT	150nF 5% 50VDC	ERO	MKT 1826-415/06 4-G	11.181
C4-3	CAPACITOR MKT	150nF 5% 50VDC	ERO	MKT 1826-415/06 4-G	11.181
C7-3	CAPACITOR MKT	150nF 5% 50VDC	ERO	MKT 1826-415/06 4-G	11.181
C9-3	CAPACITOR MKT	150nF 5% 50VDC	ERO	MKT 1826-415/06 4-G	11.181
C11-3	CAPACITOR MKT	150nF 5% 50VDC	ERO	MKT 1826-415/06 4-G	11.181

POSITION	DESCRIPTION		MANUFACTOR	TYPE	S.P.NUMBER
C13-3	CAPACITOR MKT	150nF 5% 50VDC	ERO	MKT 1826-415/06 4-G	11.181
C15-3	CAPACITOR MKT	150nF 5% 50VDC	ERO	MKT 1826-415/06 4-G	11.181
C17-3	CAPACITOR MKT	150nF 5% 50VDC	ERO	MKT 1826-415/06 4-G	11.181
C18-3	CAPACITOR MKT	150nF 5% 50VDC	ERO	MKT 1826-415/06 4-G	11.181
C19-3	CAPACITOR MKT	150nF 5% 50VDC	ERO	MKT 1826-415/06 4-G	11.181
C20-3	CAPACITOR MKT	150nF 5% 50VDC	ERO	MKT 1826-415/06 4-G	11.181
C21-3	CAPACITOR MKT	150nF 5% 50VDC	ERO	MKT 1826-415/06 4-G	11.181
C22-3	CAPACITOR ELECTROLYTIC	47uF 20% 25VDC	ELNA	RJ2-25-V-470-M-F1	14.524
C23-3	CAPACITOR MKT	15nF 5% 250V	ERO	MKT1818	11.170
C24-3	CAPACITOR MKT	4.7NF 100V 10%	ERO	MKT1818-247/01-5G	11.145
C25-3	CAPACITOR MKT	150nF 5% 50VDC	ERO	MKT 1826-415/06 4-G	11.181
C26-3	CAPACITOR MKT	150nF 5% 50VDC	ERO	MKT 1826-415/06 4-G	11.181
C28-3	CAPACITOR MKT	150nF 5% 50VDC	ERO	MKT 1826-415/06 4-G	11.181
C29-3	CAPACITOR MKT	150nF 5% 50VDC	ERO	MKT 1826-415/06 4-G	11.181
C30-3	CAPACITOR MKT	150nF 5% 50VDC	ERO	MKT 1826-415/06 4-G	11.181
D1-3	DIODE	1N4148 HIGH SPEED	PHILIPS	1N4148-143	25.131
D5-3	DIODE	1N4148 HIGH SPEED	PHILIPS	1N4148-143	25.131
D6-3	DIODE	1N4148 HIGH SPEED	PHILIPS	1N4148-143	25.131
D7-3	DIODE	1N4148 HIGH SPEED	PHILIPS	1N4148-143	25.131
D8-3	DIODE	1N4148 HIGH SPEED	PHILIPS	1N4148-143	25.131
D9-3	DIODE	1N4148 HIGH SPEED	PHILIPS	1N4148-143	25.131
D10-3	DIODE	1N4148 HIGH SPEED	PHILIPS	1N4148-143	25.131
D11-3	DIODE	1N4148 HIGH SPEED	PHILIPS	1N4148-143	25.131
D12-3	DIODE	1N4148 HIGH SPEED	PHILIPS	1N4148-143	25.131
D13-3	DIODE	1N4148 HIGH SPEED	PHILIPS	1N4148-143	25.131
D14-3	DIODE	1N4148 HIGH SPEED	PHILIPS	1N4148-143	25.131
D15-3	DIODE	1N4148 HIGH SPEED	PHILIPS	1N4148-143	25.131
D16-3	DIODE	1N4148 HIGH SPEED	PHILIPS	1N4148-143	25.131
D17-3	DIODE	1N4148 HIGH SPEED	PHILIPS	1N4148-143	25.131
J1-3	SOCKET	2x7 POLES	AMP	1-215079-4	78.196
J2-3	SOCKET	2x7 POLES	AMP	1-215079-4	78.196
OC1-3	OPTO COUPLER	DUAL DARLINGTON	TOSHIBA	TLP 523-2	32.536
OC2-3	OPTO COUPLER	DUAL DARLINGTON	TOSHIBA	TLP 523-2	32.536
OC3-3	OPTO COUPLER	DUAL DARLINGTON	TOSHIBA	TLP 523-2	32.536
P1-3	PLUG	1/10" SIL SQ.PINS 2 POLES	AMP	0-826629-2	78.322
P2-3	PLUG	1/10" SIL SQ.PINS 2 POLES	AMP	(0-826647-2) 0-826629-2	78.322
P3-3	PLUG	2x7 POLES	3M	3598-6002 / 7614-6002 JL	78.254
Q2-3	TRANSISTOR AF POWER NPN	DARLINGTON BD645/BDX53	PHILIPS	BD645	29.122
R1-3	RESISTOR MF	1k0 OHM 5% 0.33W	PHILIPS	2322 180 73102	02.472
R2-3	RESISTOR MF	1k0 OHM 5% 0.33W	PHILIPS	2322 180 73102	02.472
R3-3	RESISTOR MF	10k OHM 5% 0.33W	PHILIPS	2322 180 73103	02.496
R4-3	RESISTOR MF	1k0 OHM 5% 0.33W	PHILIPS	2322 180 73102	02.472
R5-3	RESISTOR MF	1k0 OHM 5% 0.33W	PHILIPS	2322 180 73102	02.472
R6-3	RESISTOR MF	1k0 OHM 5% 0.33W	PHILIPS	2322 180 73102	02.472
R7-3	RESISTOR MF	1k0 OHM 5% 0.33W	PHILIPS	2322 180 73102	02.472
R8-3	RESISTOR MF	10k OHM 5% 0.33W	PHILIPS	2322 180 73103	02.496
R9-3	RESISTOR MF	1k0 OHM 5% 0.33W	PHILIPS	2322 180 73102	02.472
R10-3	RESISTOR MF	1k0 OHM 5% 0.33W	PHILIPS	2322 180 73102	02.472
R11-3	RESISTOR MF	1k0 OHM 5% 0.33W	PHILIPS	2322 180 73102	02.472
R12-3	RESISTOR MF	1k0 OHM 5% 0.33W	PHILIPS	2322 180 73102	02.472
R13-3	RESISTOR MF	10k OHM 5% 0.33W	PHILIPS	2322 180 73103	02.496
R14-3	RESISTOR MF	1k0 OHM 5% 0.33W	PHILIPS	2322 180 73102	02.472
R15-3	RESISTOR MF	1k0 OHM 5% 0.33W	PHILIPS	2322 180 73102	02.472
R16-3	RESISTOR MF	1k0 OHM 5% 0.33W	PHILIPS	2322 180 73102	02.472
R17-3	RESISTOR MF	1k0 OHM 5% 0.33W	PHILIPS	2322 180 73102	02.472
R18-3	RESISTOR MF	10k OHM 5% 0.33W	PHILIPS	2322 180 73103	02.496
R19-3	RESISTOR MF	1k0 OHM 5% 0.33W	PHILIPS	2322 180 73102	02.472
R20-3	RESISTOR MF	1k0 OHM 5% 0.33W	PHILIPS	2322 180 73102	02.472
R21-3	RESISTOR MF	100k OHM 5% 0.33W	PHILIPS	2322 180 73104	02.520
R22-3	RESISTOR MF	47k OHM 5% 0.33W	PHILIPS	2322 180 73473	02.512
R23-3	RESISTOR MF	68k OHM 5% 0.33W	PHILIPS	2322 180 73683	02.516
R24-3	RESISTOR MF	4k7 OHM 5% 0.33W	PHILIPS	2322 180 73472	02.488
R25-3	RESISTOR MF	1M OHM 5% 0.33W	PHILIPS	2322 180 73105	02.544
R27-3	RESISTOR MF	10k OHM 5% 0.33W	PHILIPS	2322 180 73103	02.496
R28-3	RESISTOR MF	10k OHM 5% 0.33W	PHILIPS	2322 180 73103	02.496
R29-3	RESISTOR PMF	220 OHM 5% 2W	PHILIPS	2322 194 13221	04.183

POSITION	DESCRIPTION		MANUFACTOR	TYPE	S.P.NUMBER
R30-3	RESISTOR MF	220 OHM 5% 0.4W	PHILIPS	2322 181 53221	01.183
R31-3	RESISTOR MF	1k0 OHM 5% 0.33W	PHILIPS	2322 180 73102	02.472
R32-3	RESISTOR MF	1k0 OHM 5% 0.33W	PHILIPS	2322 180 73102	02.472
R33-3	RESISTOR MF	10k OHM 5% 0.33W	PHILIPS	2322 180 73103	02.496
R34-3	RESISTOR MF	1k0 OHM 5% 0.33W	PHILIPS	2322 180 73102	02.472
R35-3	RESISTOR MF	1k0 OHM 5% 0.33W	PHILIPS	2322 180 73102	02.472
R36-3	RESISTOR MF	10k OHM 5% 0.33W	PHILIPS	2322 180 73103	02.496
R37-3	RESISTOR MF	10k OHM 5% 0.33W	PHILIPS	2322 180 73103	02.496
R38-3	RESISTOR MF	10k OHM 5% 0.33W	PHILIPS	2322 180 73103	02.496
R39-3	RESISTOR MF	470 OHM 5% 0.33W	PHILIPS	2322 180 73471	02.464
U1-3	QUAD R-S LATCH	MC14043BCP	SIGNETICS	HEF 4043 BP	33.160
U2-3	QUAD R-S LATCH	MC14043BCP	SIGNETICS	HEF 4043 BP	33.160
U3-3	INTEGRATED CIRCUIT	MC14069UBCP	MOTOROLA	MC14069UBCP	33.235
U4-3	QUAD 2-INPUT "OR" GATE	MC14071BCP	SIGNETICS	HEF 4071 BP	33.245
U5-3	POS. VOLTAGE REG. FIXED	15V/1A MC7815/LM340T	MOTOROLA	MC7815CT	31.090

## CONNECTION BOARD (4)

H2184

5-0-28780 / 4-0-28780B

628780

POSITION	DESCRIPTION		MANUFACTOR	TYPE	S.P.NUMBER
D1-4	DIODE RECTIFIER	1N4002 100V/1A	THOMSON	1N4002 (03/04/05/06/07)	25.100
D2-4	DIODE RECTIFIER	1N4002 100V/1A	THOMSON	1N4002 (03/04/05/06/07)	25.100
D3-4	DIODE RECTIFIER	1N4002 100V/1A	THOMSON	1N4002 (03/04/05/06/07)	25.100
D4-4	DIODE RECTIFIER	1N4002 100V/1A	THOMSON	1N4002 (03/04/05/06/07)	25.100
F1-4	FUSE	2AT 250V 5x20mm	ELU	179 120 2AT	45.508
F2-4	FUSE	2AT 250V 5x20mm	ELU	179 120 2AT	45.508
P1-4	PLUG	2x7 POLES	3M	3598-6002 / 7614-6002 JL	78.254
ST1-4	TERMINAL BLOCK	15 POLES 1.5mm2	PTR	AK300/15b m.MESS.SKRUER BLÅ	81.022
ST2-4	TERMINAL BLOCK	10 POLES 1.5mm2	PTR	AK300/10b m.MESS.SKRUER BLÅ	81.017